



brands you trust.



Crane®FKX 9000
Next Generation Triple Offset Valves



Crane ChemPharma & Energy

www.cranecpe.com

Heritage of Innovation & Quality

Crane Co. is a diversified manufacturer of highly engineered industrial products, founded in 1855. Crane has approximately 11,000 employees in the Americas, Europe, Asia and Australia, and is traded on the New York Stock Exchange (NYSE:CR).

Since its foundation in 1855, Crane has been a symbol of manufacturing excellence, expanding alongside the global industrial revolution and shaping the growth of industry worldwide. Crane ChemPharma & Energy, within Crane's Fluid Handling segment, is proud to be a part of the company's illustrious history,

delivering solutions to the fluid handling challenges faced by the industry's most demanding applications.

From the industrial revolution to the modern age, Crane has anticipated the challenges of the market and developed progressive solutions to address them. A comprehensive product portfolio backed by a robust global infrastructure enables Crane CP&E to deliver localized solutions to the chemical processing, biotechnology, pharmaceutical, oil & gas, refining, and power generation industries worldwide. Crane CP&E's

highly-engineered offering includes check valves, sleeved plug valves, lined valves, process ball valves, high-performance butterfly valves, bellows sealed globe valves, aseptic and industrial diaphragm valves, multi/quarter-turn valves, actuation, sight glasses, lined pipe, fittings and hoses, and air operated diaphragm and peristaltic pumps.

With offices, manufacturing plants, distribution networks, and sales & service centers that span the globe, Crane CP&E is a worldwide leader in fluid handling products and solutions.

Crane Fluid Handling: Global Presence, Local Support.



Traceability

A stainless steel, tag is attached to all manufactured and modified valves. It includes standard ASME or DIN information.

Fully Tested

All of our valves are tested in accordance with Crane's strict manufacturing procedures and industry regulations.

Field Repair Services

Crane® technicians are available for field repair and emergency service at your site.

Consistent Quality

Crane's high quality standards are supported by our extensive practical experience, state-of-the-art manufacturing, and quality assurance certified by international inspections authorities. Please visit our website for details.

Features and Benefits

The Crane®FKX 9000 Triple Offset Valve design is recommended for industrial applications requiring reliable zero-leakage, bi-directional shut-off in harsh conditions of critical processes, steam isolation, and temperature extremes, especially when use of soft-seated materials in valves is limited.

Compared to other valves used in these applications, the Crane®FKX 9000 Triple Offset Valves is an affordable solution, particularly in larger diameter installations, that requires less structural support to ensure bubble tight shut-off. The result is a zero leakage shut-off even in high-pressure, high-temperature applications. Due to their quarter-turn movement for opening and closing, the valves are easy to automate and they can fulfill a quick closing time, which is often required in safety applications.

- 1 Optimized Seat Angle:** An innovative seat angle design and Stellite® hard-faced valve body seat deliver a longer seal life and improved abrasion resistance, even after extensive cycling. Designed to eliminate wedging or binding of the disc, and lower the operating torque, the Crane®FKX 9000 can **REDUCE TOTAL COST OF OWNERSHIP BY UP TO 50%.***
- 2 Metal-to-Metal Sealing:** The precision machined metal seat and seal ring deliver reliable and bi-directional shutoff in high-temperature, high-pressure and severe service applications, among others. The right-angle conical seat design facilitates an almost **FRICTIONLESS IN-LINE SEALING.**
- 3 Innovative Shaft Seal Design:** permits superior FUGITIVE EMISSIONS CONTROL (ISO 15848, Class AH) under recurrent thermal cycling, and **REDUCES POTENTIAL DOWN TIME.**
- 4 Torque-Seating:** Unlike position-seated ball, butterfly or plug valves, the torque-seated Crane®FKX 9000 self-adjusts to evenly distribute seal compression. A “floating” seal ring and wide seal ring supporting gasket yield a **BETTER SEAL** to eliminate binding and to enhance performance.

*Proven against leading TOV supplier, in customer's Methyl Diisocyanates application

What is a TOV?

As the name implies, there are three separate offsets designed into the valve. Two of the offsets apply to the location of the shaft with respect to the center line of the bore and the center line of the disc/seat sealing surfaces. The third offset in the design is the axis of the seat cone angle that is inclined from the center line of the valve bore. This eliminates rubbing of the seat/seal contact surfaces during operation and preserves sealing integrity over the cycle life of the valve. The contact is made in only the final point of closure, acting as a mechanical travel stop which prohibits over-travel of the disc.

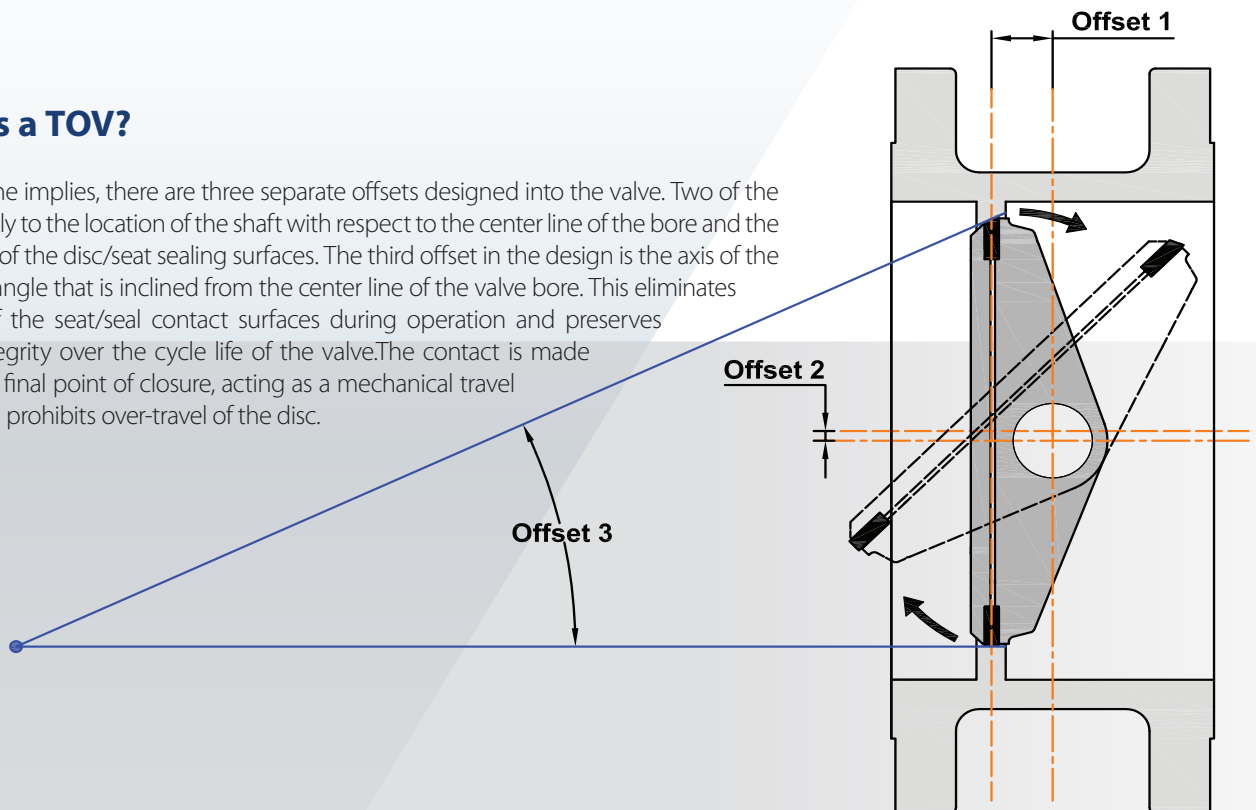

Applications and Method of Control

A triple eccentric or triple offset butterfly valve should be used when the application requires bubble tight shut-off, but does not allow the use of a rubber-lined butterfly valve due to low/high temperatures and high pressure. The triple offset design can be used for on/off services, throttling services and modulating services.

- **On/Off Service:** Like the name suggests, on/off valves are designed to shutoff and to open fully but lack the ability to regulate effectively through the range of travel.
- **Throttling Service:** Throttling service (sometimes referred to as inching) is in general flow control through the system where the valve is set and held in an intermediate position.

- **Modulating Service:** Modulating service (known also as regulating service) is used to drive the valve frequently to any position between fully open and fully closed to control the flow. It uses feedback from the field, and valve disc position is adjusted almost continuously.

Quarter turn valves are usually limited to a throttling range of ~25° to ~75° open (25% to 85%). In case of throttling the manufacturer should be consulted in order to predict whether the control valve was installed accurately.

Flow Characteristic

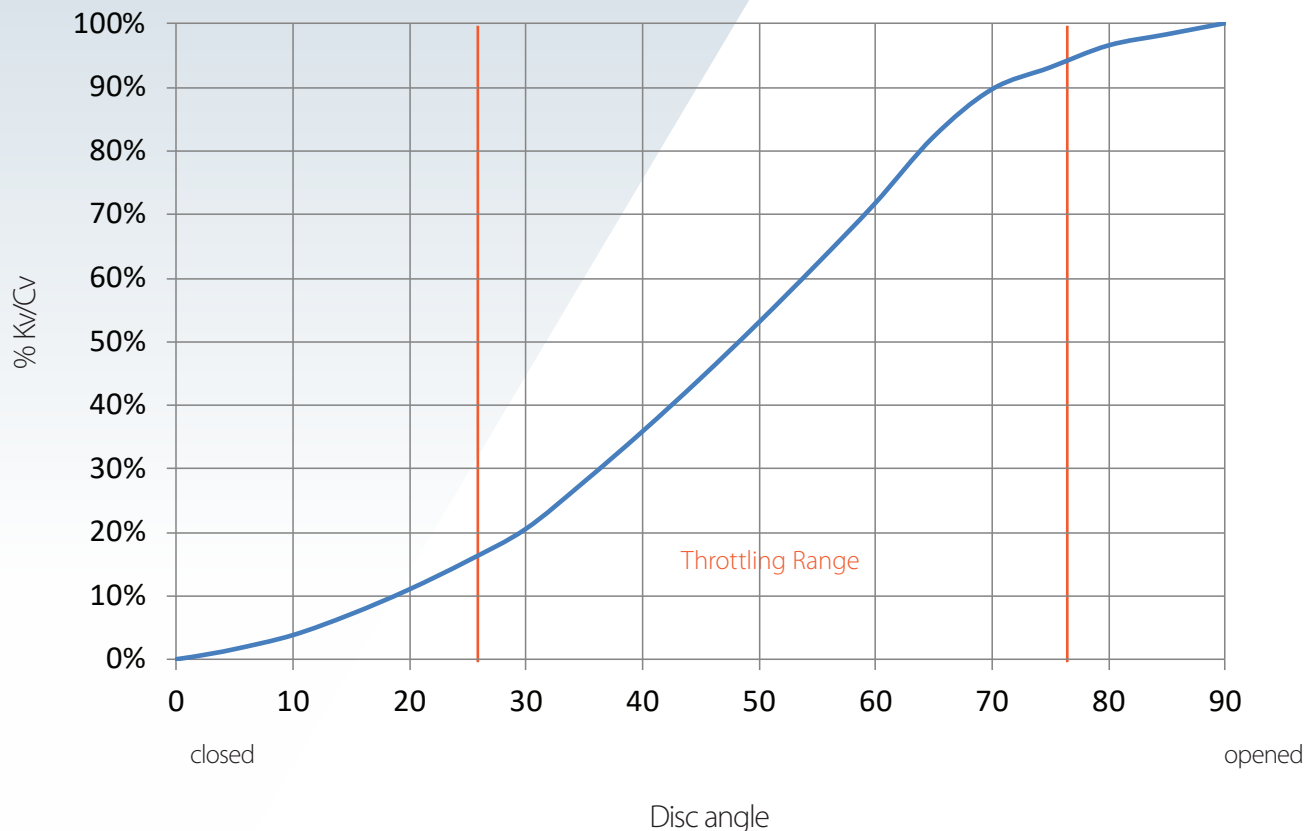

Applications

Industries

- Oil & Gas
- Refineries
- Hydrocarbons Storage & Transportation
- Chemical & Petrochemical Plants
- Power Generation
- Offshore Platforms
- District Heating
- Pulp & Paper
- Steel Mills
- Sugar Mills
- Desalination Plants
- Water Treatment & Distribution

Processes

- Steam (Saturated & Superheated)
- Hydrocarbons
- Hydrogen
- Oxygen
- Hot gases
- Sulphur (Tail Gas)
- Chlorinated Solvents
- Flare Gas
- Chemical Solvents

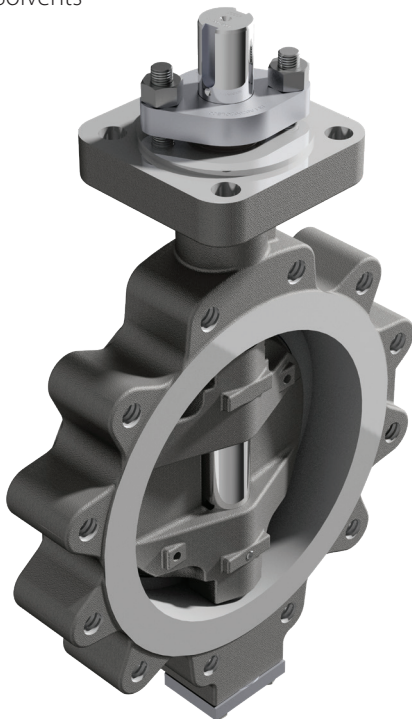

Crane®FKX 9000 - Performance Chart

● Well suited ● Limited application

| FUNCTION | FUNCTION | |
|----------------------------|---------------------------|--------------------------|
| | On / Off | ● |
| | Throttling | ● |
| MEDIA TYPES | MEDIA TYPES | |
| | Clean Liquids & Gases | ● |
| | Dirty Liquids & Gases | ● |
| | Corrosive Liquids & Gases | ● |
| | Hazardous Liquids | ● |
| | Viscous Liquids | ● |
| | Abrasive Slurries | ● |
| | Extreme Temperatures | ● |
| | Vacuum Service | ● |
| | APPLICATION REQUIREMENTS | APPLICATION REQUIREMENTS |
| Extended Service Life | | ● |
| Low Torque | | ● |
| Fugitive Emissions Control | | ● |
| Minimal Space Requirements | | ● |
| Reduced Maintenance | | ● |
| Bi-directional | | ● |
| Sizes | | 3"-64" , DN 80-1600 |
| Pressure Range | | Class 150-600, PN10-100 |
| High Temperature | | 1022°F / 550°C |
| Low Temperature | -76°F / -60°C | |

Design Features

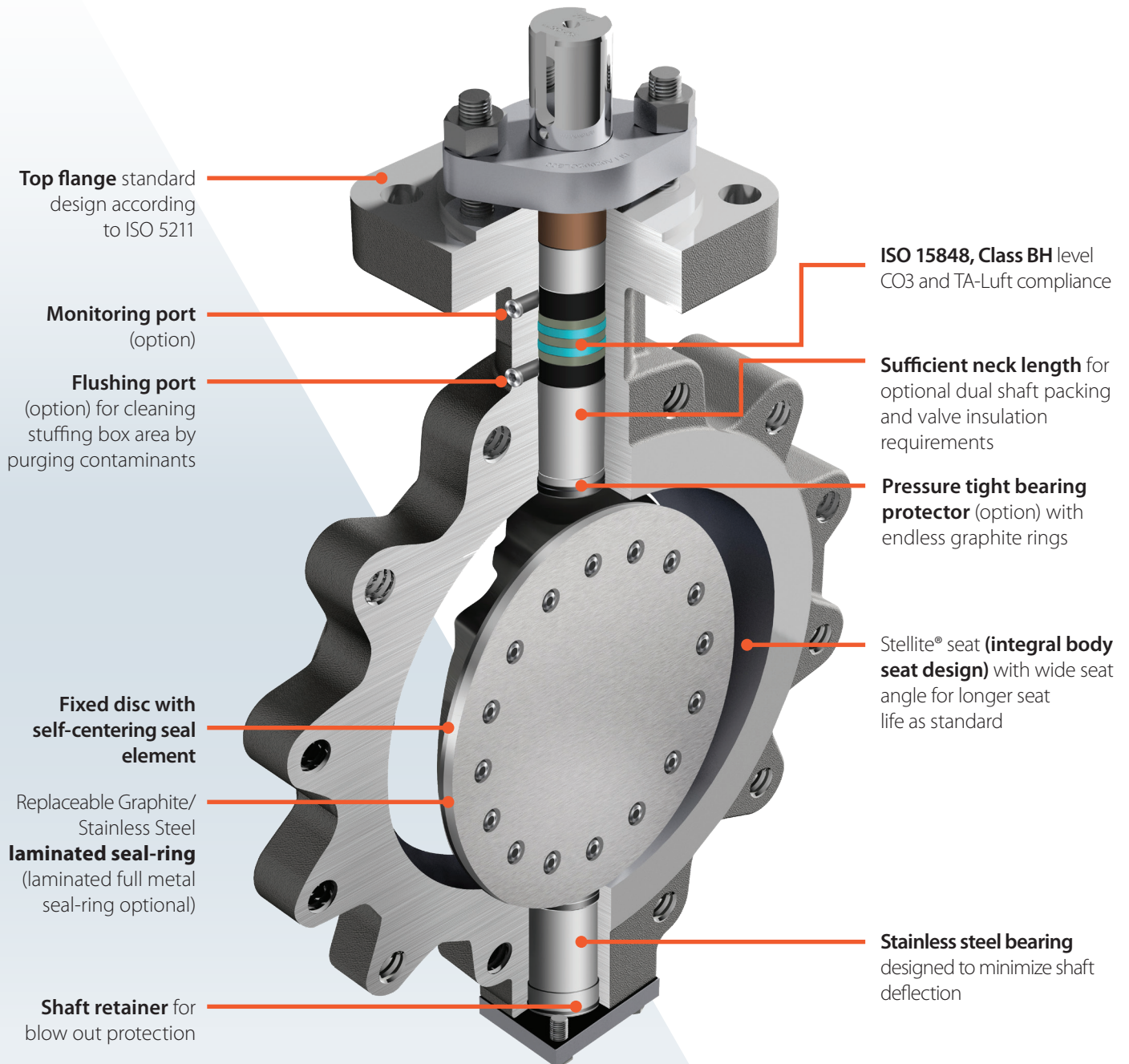

Standard Design Features

Optimized Seat Angle

- Innovative wide seat angle design, relying on a “self-releasing taper” principle, minimizes binding or galling of the seal-ring, especially in severe service and abrasive applications which results in longer leak-tight service life.
- Crane®FKX 9000 optimized offset design minimizes operational torque value needed to provide leak-tight shutt-off.

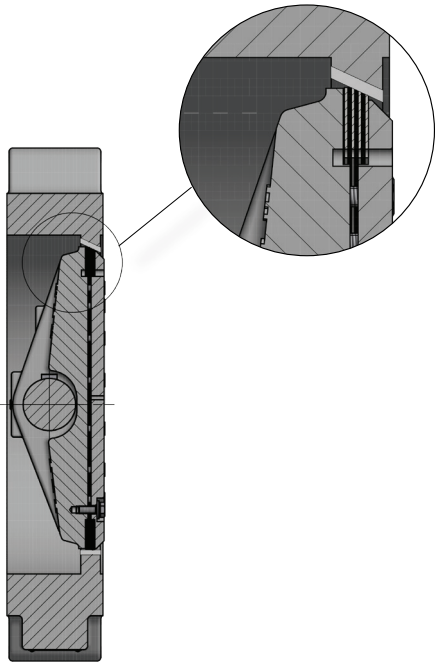
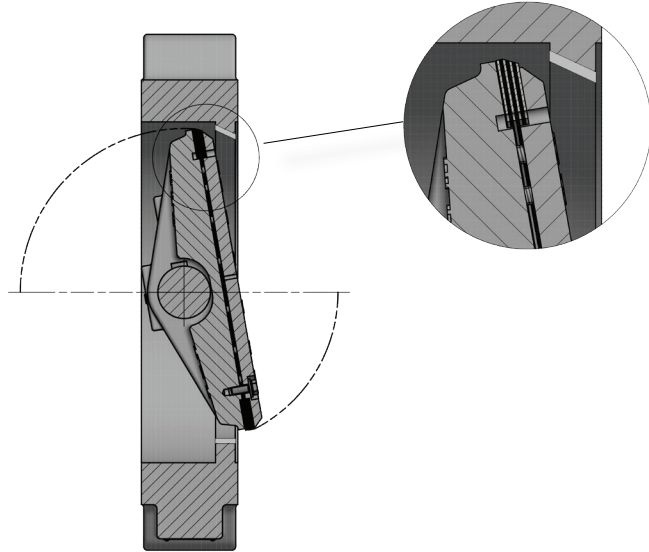

Metal to Metal Sealing and Wide Gasket Design

- Metal-to-metal sealing between the seal ring and the body seat allows for high temperature, high pressure, and severe service handling, while still achieving zero-leakage sealing performance.
- Super fine surface finish provides a near frictionless sealing
- Thick seal ring design differentiates against thinner seal rings offered by competition, to provide a robust and long lasting sealing element with a large sealing surface.

Standard Design Features

Innovative Shaft Seal Design

- Special graphite compound and unique manufacturing process permits superior fugitive emissions control.
- Optimized shaft finish reduces abrasion on the packing design, which ensures leak tight operations after many re-occurring cycles.
- Superfine finish and optimized design of the body, shaft and internal shaft components prevents extrusion of the packing and thereby prevents leakage even after many recurring cycles.
- Additional bearing protector provides a seal against contamination from the media into the shaft bearing area to prevent damage to the packing from the media.
- The innovative and unique features of our shaft seal design allow us to reach ISO, 15848 Class BH under recurring thermal cycles. Exceeding even TA-Luft standards, the shaft seal design provides a leak tight performance under many recurring cycles, reducing potential down time and spare part costs, and ensuring valve operator safety for our customers worldwide.

STANDARD

- ISO 15848, Class BH, level CO3
- TA-Luft
- EPA Method 21 (Fugitive Emissions Compliance)
- API 641

OPTIONAL

- ISO 15848 Class AH, level CO2
- Pressure tight bearing
- Dual Packing
- Monitoring Port
- Flushing Port

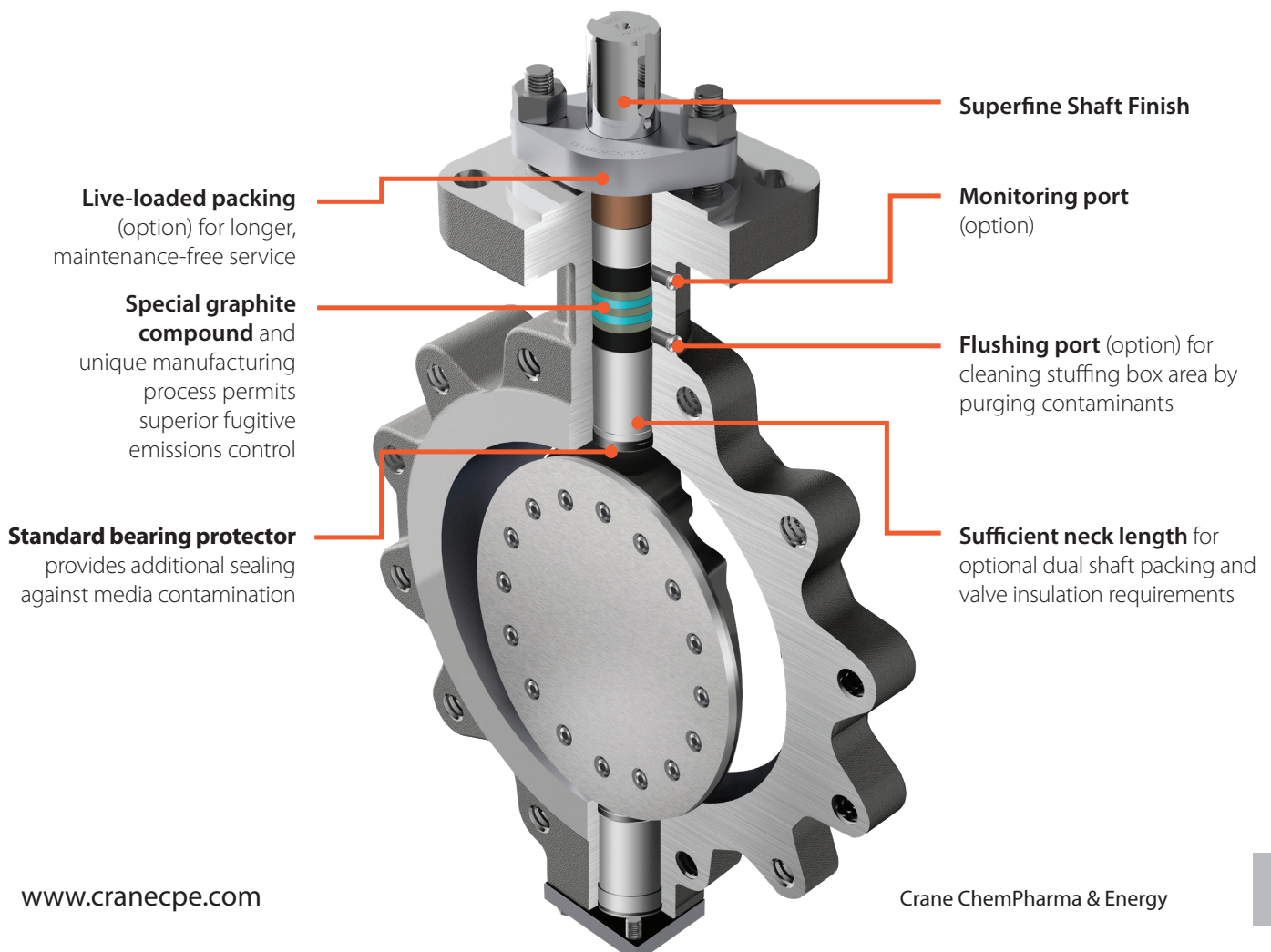

Standard Design Features

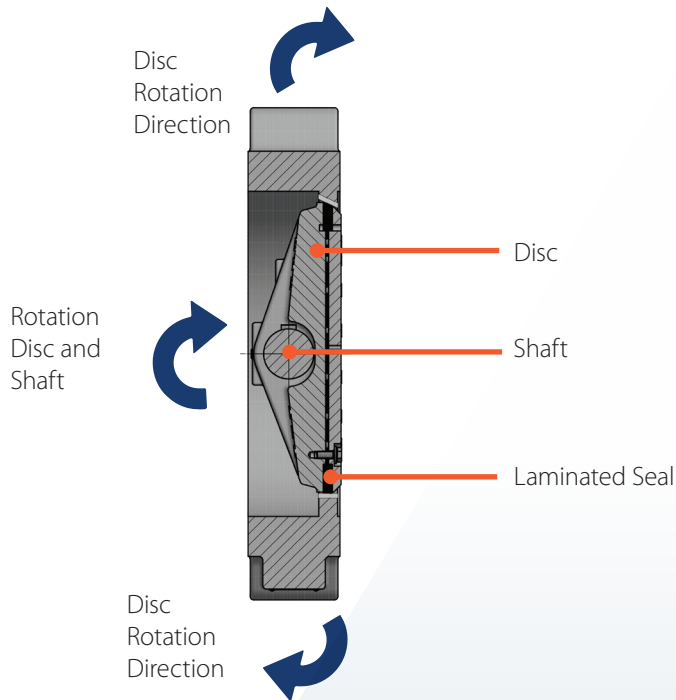

Torque-Seating

- Unlike position-seated ball, butterfly or plug valves, the Crane®FKX 9000 is a torque-seated valve.
- The sealing occurs due to self-adjustment of the “floating” seal ring and the applied torque.
- A slight increase in torque yields a better seal due to a more evenly distributed compression of the seal ring along the entire sealing area. The applied torque also ensures a bi-directional seal.

Blow-Out Proof Shaft

- Double safety feature to ensure maximum safety for the valve operator.
- Provided by the bottom shaft fixing pin with shaft retainer/split ring as a primary blow-out safety feature and upper shaft retainer as a secondary blow-out safety feature.

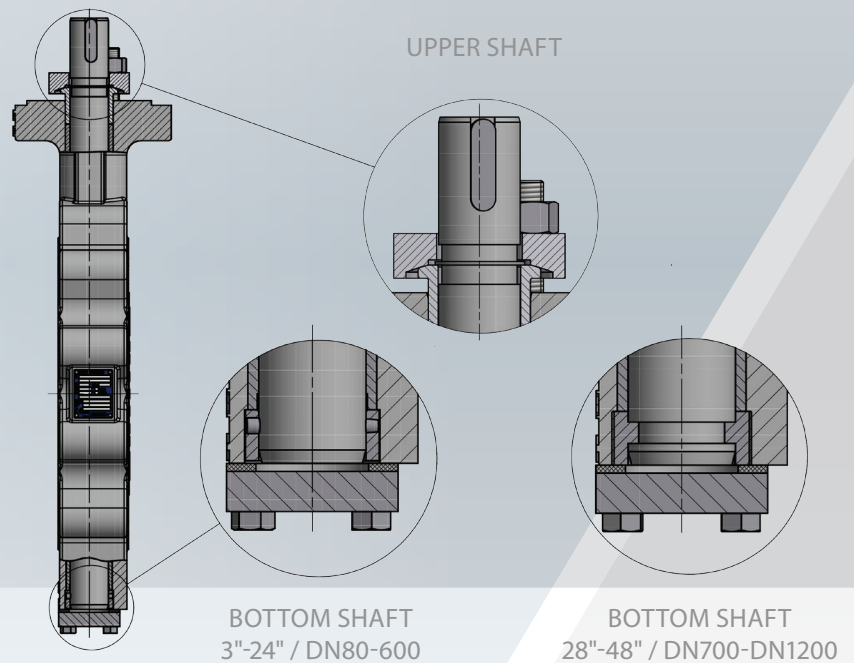

Standard Design Features and Heating Jacket Design

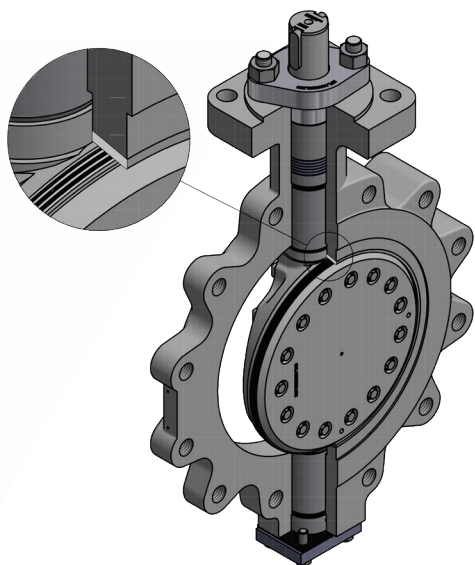

Integral Body Seat Design

- Cast in integral body seat with hard face overlay in Stellite 21 is designed for durability.
- Excellent resistance to thermal shocks provides less thermal misalignments
- Resistant to erosion and abrasion, resulting in a long life
- Resistant to flex
- Long Life +50,000 cycles
- Plasma Stellite overlay provides a denser metal deposition with minimal HAZ (considered the most effective and tenacious hard facing technology available).
- Most competitors use a bolted in design, which in comparison to the rigid integral body, has mechanical movement in both disc seat and body seal which creates susceptibility to premature leaking.

Heating Jacket

- Heating jackets are required where the process temperature must be maintained through the valve in order to keep the process media fluid.
- In particular, where there is potential for media to be trapped within a closed valve, the heating jacket can be vital in maintaining the process temperature and preventing the trapped product from solidifying.

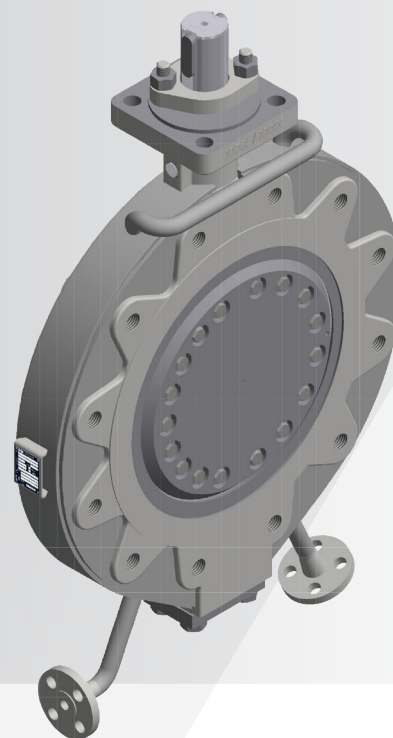

Bearing Protectors and Packing Designs

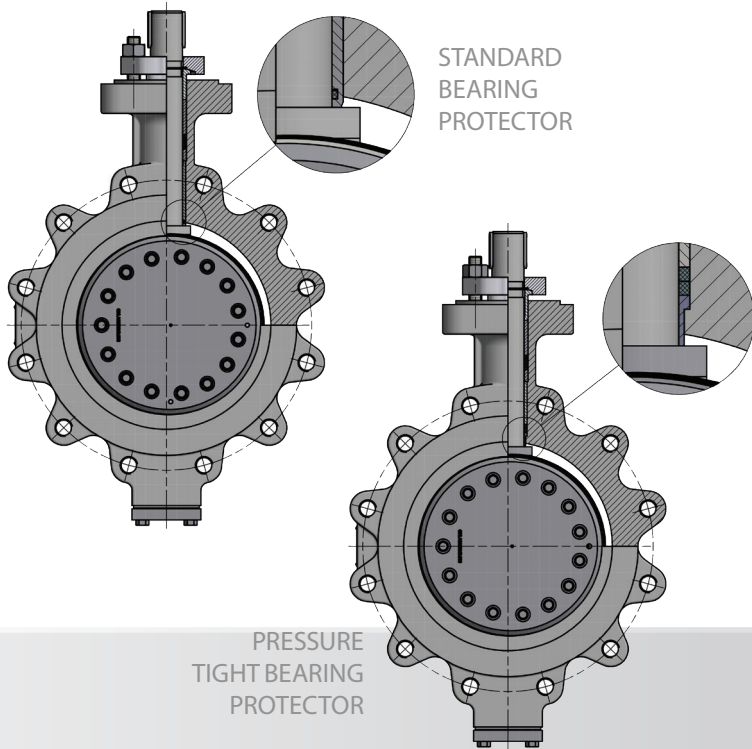

STANDARD BEARING PROTECTOR

PRESSURE TIGHT BEARING PROTECTOR

Pressure Tight Bearing Protector

- Crane®FKX 9000's optional pressure tight bearing protection prevents polymerization, solidification or crystallization of fluids and vapors in bearing areas.
- The Pressure Tight Bearing Protection was specifically designed to address these pain points. Its unique features create additional sealing that prevents vapors or fluids from permeating into the bearing/bushing region of the stem, improving safety for the valve operator and increasing valve life.

Dual Packing with Port Options

- The dual packing is used in combination with the monitoring port, providing a double shaft sealing and enabling leakage detection under critical conditions as a safety feature.
- The flushing port allows the stuffing box to be cleaned by purging contaminants.

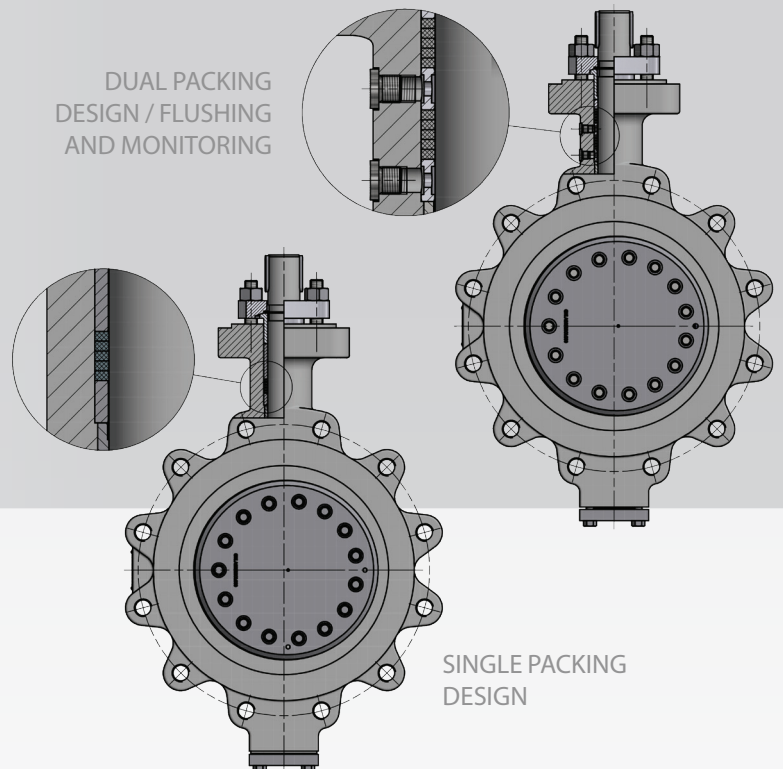

DUAL PACKING DESIGN / FLUSHING AND MONITORING

SINGLE PACKING DESIGN

Gland Flange Designs

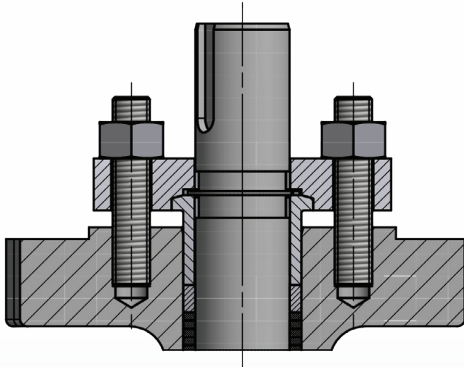

Standard Packing Gland Design

- Standard packing gland design prevents contamination of the packing
- Durable two piece gland flange design
- Provides a constant packing compression
- Reduces fugitive emissions and side load to shaft

Chemical Packing Gland Design



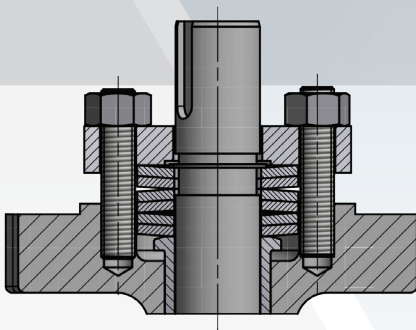
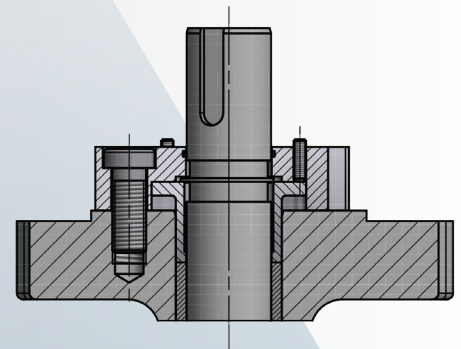





- Standard packing gland design prevents contamination of the packing
- Gapless gland flange assembly onto valve's top flange
- Integrated O-ring prevents outside dirt from entering the inside of the valve and packing
- Pressure pin and pressure ring for adjustment of the packing compression

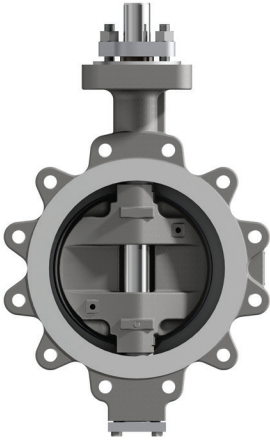

Live-Loaded Gland Design

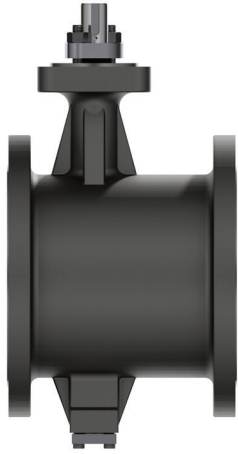
- Live-loaded packing as option for longer, maintenance-free service
- One spring column between gland and gland flange
- Provides a constant packing compression
- Lower maintenance intervals when used under difficult operating conditions with high switching cycles and lower thermal load

Body Designs

| | Lug Design | Double Flanged Short Pattern Design | Double Flanged Long Pattern Design |
|-------------------------|---|---|---|
| Front View - Shaft Side |  |  |  |
| Side View |  |  |  |
| Top View |  |  |  |

Fugitive Emission Testing

Fugitive Emissions Testing According to ISO 15848-1: 2015

Capitalizing on the standard TOV design features Crane's next generation Crane®FKX 9000 Triple Offset Valve is capable of better handling the harsh conditions of critical process applications, steam isolation and temperature extremes.

The unique stem seal design provides superior fugitive emissions control (ISO 15848, Class AH) under recurrent and extreme thermal cycling not typically seen in TOVs. This increased control classification has historically only been associated with bellows-sealed valves.

Through the use of use of graphite packing to accommodate higher temperatures, the stem seal design and packing assembly method used in the new TOV design of today enables this classification level.

Additionally, depending on the application in which it is used, the packing offering of new TOVs can be differentiated so users can choose which works best for their needs:

- TA-Luft acc. to VDI 2440
- Standard (Process Industry): ISO 15848-1&2: Class BH CO3 (< 100 ppmv)
- Low-E Option: ISO 15848-1&2: Class AH CO2 (< 50 ppmv)
- EPA Method 21 (Fugitive Emissions Compliance)
- API 641

ISO FE BH CO3-SSA1-t(RT, 400 °C)-class 300-ISO 15848-1

| Class | Measured leak rate ^a mg s ⁻¹ m ⁻¹ | Remarks |
|----------------|--|---|
| A ^b | ≤ 10 ⁻⁵ | Typically achieved with bellow seals or equivalent stem (shaft) sealing system for quarter turn valves. |
| B | ≤ 10 ⁻⁴ | Typically achieved with PTFE based packings or elastomeric seals. |
| C | ≤ 10 ⁻² | Typically achieved with flexible graphite based packings. |

^a Expressed in mg s⁻¹ m⁻¹ measured with total leakage method.
^b Class A can be measured only with helium using the vacuum method.

| Test Fluid | Class |
|-------------|------------|
| H - Helium | AH, BH, CH |
| M - Methane | BM, CM |

When the test fluid is helium, classes are identified as AH, BH and CH. When the test fluid is methane, classes are identified as BM and CM.

| Classification | Minimum number of mechanical cycles |
|----------------|---|
| CO1 | 205 cycles, with two thermal cycles (except for RT) |
| CO2 | 1.500 cycles, with three thermal cycles |
| CO3 | 2.500 cycles, with four thermal cycles |

| Number of Adjustments |
|-----------------------|
| 0 / 1 / 2 / 3 |

| Temperature Classes | | | | |
|---------------------|-----------|----------------------|-----------|-----------|
| (t-196 °C) | (t-46 °C) | (tRT -29 °C/+40 °C) | (t200 °C) | (t400 °C) |
| -196 °C | -46 °C | Room temperature, °C | 200 °C | 400 °C |

| Part Composition | |
|---|---|
| Part 1 (Design) | Part 2 (Production) |
| System of classification and procedures of qualification for the tests of the type of the valves. | Acceptance tests in production of the valves - Non-destructive. |

| Pressure Rate |
|---------------|
| Class 150 |
| Class 300 |
| Class 600 |
| PN 10 |
| PN 16 |
| PN 25 |
| PN 40 |
| PN 63 |
| PN 100 |

CRANE®

Crane ChemPharma & Energy
4526 Research Forest Drive, Suite 400
The Woodlands
Texas 77381, U.S.A.
Tel.: +1 936 271 6500
Fax: +1 936 271 6510
www.cranecpe.com

Friedrich Krombach GmbH
Armaturenwerke
Marburger Str. 364
57223 Kreuztal, Germany
Tel: +49 2732 520 00
Fax: +49 2732 520 100

brands you trust.



CPE-CRANE-FKX 9000-BU-EN-LT-2020_06_17

Crane Co. and its subsidiaries cannot accept responsibility for possible errors in catalogues, brochures, other printed materials, and website information. Crane Co. reserves the right to alter its products without notice, including products already on order provided that such alteration can be made without changes being necessary in specifications already agreed. All trademarks in this material are property of the Crane Co. or its subsidiaries. The Crane and Crane brands logotype, in alphabetical order, (ALOYCO®, CENTER LINE®, COMPAC-NOZ®, CRANE®, DEPA®, DUO-CHEK®, ELRO®, FLOWSEAL®, JENKINS®, KROMBACH®, NOZ-CHEK®, PACIFIC VALVES®, RESISTOFLEX®, REVO®, SAUNDERS®, STOCKHAM®, TRIANGLE®, UNI-CHEK®, WTA®, and XOMOX®) are registered trademarks of Crane Co. All rights reserved.